



Instruction Manual

symphony™ Incubating Orbital Shaker Model 3500

symphony™ Incubating Orbital Shaker Model 5000I

symphony™ Incubating Refrigerating Orbital Shaker Model 5000IR

TABLE OF CONTENTS

Package Contents	1
Warranty	1
Installation	2
Maintenance & Servicing	2
Environmental Conditions	2
Safety Instructions	3
Standards & Regulations	3
Control Panel	4
Specifications	5-6
5000IR Upper Ambient Control Limit	7
Operating Instructions	8-11
Troubleshooting	12
Replacement Parts	13-18
Accessories	19-20

PACKAGE CONTENTS

Incubating Orbital Shaker
Non-skid rubber mat
92" (234cm) detachable power cord
Instruction manual

WARRANTY

Manufacturer warrants this product to be free from defects in material and workmanship when used under normal conditions for two (2) years. Five (5) year limited warranty on motor and drive mechanism. Register your equipment or instrument online at: www.vwrsp.com/warranty for US residents or www.vwrcanlab.com/warranty for Canadian residents. For your reference, make a note of the serial number, date of purchase and supplier here.

Serial No.: _____ Date of Purchase: _____

Supplier: _____

INSTALLATION

Upon receiving the VWR Incubating Orbital Shaker, check to ensure that no damage has occurred during shipment. It is important that any damage that occurred in transport is detected at the time of unpacking. If you do find such damage the carrier must be notified immediately.

After unpacking, it requires at least two (2) people to lift the Incubating Orbital Shaker, from the bottom, to place on a level bench or table, away from explosive vapors. It is preferable to use a hydraulic lift or other appropriate equipment when handling the unit. **Do not lift unit by the front bezel.** Ensure that the surface on which the unit is placed will withstand typical heat produced by the unit. Always place the unit on a sturdy work surface.

The Incubating Orbital Shaker is supplied with a power cord that is inserted into the IEC connector on the back or side of the unit first, then it can be plugged into a properly grounded outlet. The 120V unit plugs into a 120 volt, 50/60 Hz source. The 230V unit plugs into a 230 volt, 50/60 Hz source.

This device complies with Part 15 rules. Operation is subject to the following two conditions:

1. This device may not cause harmful interference, and
2. This device must accept any interference received, including interference that may cause undesired operation.

MAINTENANCE & SERVICING

The Incubating Orbital Shaker is built for long, trouble-free, dependable service. No lubrication or other technical user maintenance is required. However at least every three (3) months you should:

- Unplug the unit.
- Remove any accumulated dirt from the base and tray.
- Check all accessible items to make sure they are properly tightened.

The unit should be given the care normally required for any electrical appliance. Avoid wetting or unnecessary exposure to fumes. Spills should be removed promptly. **DO NOT** use a cleaning agent or solvent on the front panel or lid which is abrasive or harmful to plastics, nor one which is flammable. Always ensure the power is disconnected from the unit prior to any cleaning. If the unit ever requires service, contact your VWR representative.

ENVIRONMENTAL CONDITIONS

Operating Conditions: Indoor use only.

Temperature:	15 to 32°C (59 to 90°F)
Humidity:	maximum 80% relative humidity, non-condensing
Altitude:	0 to 6,562 ft (2000 M) above sea level

Non-Operating Storage:

Temperature:	-20 to 65°C (-4 to 149°F)
Humidity:	maximum 80% relative humidity, non-condensing

Installation Category II and Pollution Degree 2 in accordance with IEC 664.

SAFETY INSTRUCTIONS

Please read the entire instruction manual before operating the Incubating Orbital Shaker.



WARNING! DO NOT use the Incubating Orbital Shaker in a hazardous atmosphere or with hazardous materials for which the unit was not designed. Also, the user should be aware that the protection provided by the equipment may be impaired if used with accessories not provided or recommended by the manufacturer, or used in a manner not specified by the manufacturer.

Exercise extreme caution when moving the unit as there is a risk of pinching or crushing fingers

Always operate unit on a level surface for best performance and maximum safety.

DO NOT lift unit by the tray, front bezel or lid.



CAUTION! To avoid electrical shock, completely cut off power to the unit by disconnecting the power cord from the unit or unplug from the wall outlet. Disconnect unit from the power supply prior to maintenance and servicing.

Spills should be removed promptly. **DO NOT** immerse the unit for cleaning.

DO NOT operate the unit if it shows signs of electrical or mechanical damage.



Earth Ground - Protective Conductor Terminal



Alternating Current

STANDARDS & REGULATIONS

Henry Troemner LLC hereby declares under its sole responsibility that the construction of this product conforms in accordance with the following standards:

Safety standards:

- IEC 61010-1 Safety requirements for electrical equipment for measurement, control and laboratory use. Part I: General Requirements.
- IEC 61010-2-010 Part II: Particular requirements for laboratory equipment for the heating of materials.
- IEC 61010-2-051 Part II: Particular requirements for laboratory equipment for mixing and stirring.
- UL Std. No. 61010-1
- CSA/CAN C22.2 No. 0-M91
- CSA/CAN C22.2 No. 61010-1-04

EMC standards: Incubating

FCC-B	EN45501	FCC-B	IEC 61000-4-2
EN55022-A	EN61000-3-2/3-3	IEC 61326	IEC 61000-4-3
EN61000-4-2	EN61000-4-3	IEC 61000-3-2	IEC 61000-4-4
EN61000-4-4	EN61000-4-5	IEC 61000-3-3	IEC 61000-4-5
EN61000-4-6	EN61000-4-11		IEC 61000-4-6
			IEC 61000-4-11

EMC standards: 5000I, 5000IR

Associated EU guidelines:

EMC directive 2004/108/EC
LVD directive 2006/95/EC

Patent Pending

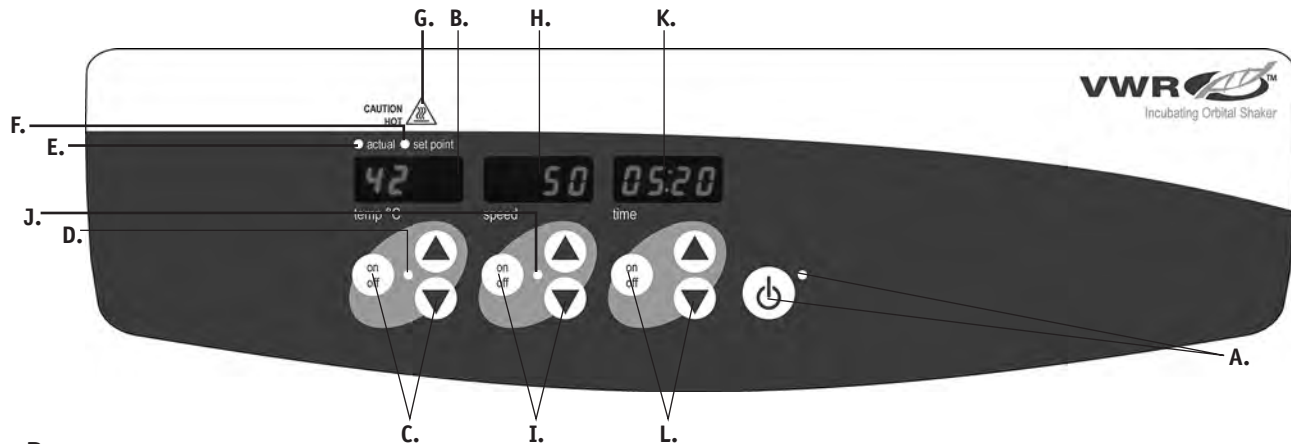

CONTROL PANEL

The front panel of the Incubating Orbital Shaker contains all the controls and displays needed to operate the unit.

A. Standby button/standby indicator light: The standby indicator light will illuminate when the unit is plugged in. The unit will be in standby mode. Press the standby button to activate the temperature, speed and time functions. The standby indicator light will shut off and the temperature, speed and time displays will illuminate. Press the standby button again and the unit will once again be in standby mode.

B. Temperature display: Displays the actual/set-point temperatures in conjunction with the actual/set-point indicator lights. **C.** Up/down arrows for set-point control. On/off button starts/stops the heating function. **D.** The heat indicator light will be illuminated when the unit is heating.

E. Actual indicator light: Illuminates when the temperature displayed is the actual temperature of the air in the chamber.

F. Set-point indicator light: Illuminates when the set-point temperature is displayed.

G. Caution hot indicator light: Illuminates when the air temperature of the chamber is above 40°C (104°F).

H. Speed display: Displays the speed of the shaker. **I.** Up/down arrows for set-point control. On/off button starts/stops shaking function. **J.** The speed indicator light will be illuminated when the unit is shaking.

K. Time display: Displays accumulated time (continuous mode) or how much time is remaining (timed mode). The display range is from 0 to 9,999 minutes in one (1) second increments. The display will indicate minutes and seconds until the timer reaches 99 minutes and 59 seconds (99:59), then the display will automatically display minutes up to 9,999. **L.** Up/down arrows for set-point control. On/off button starts/stops the time function.

**SPECIFICATIONS - symphony™ INCUBATING ORBITAL SHAKER
MODEL 3500**

Overall dimensions (L x W x H):	25.5 x 14 x 16" (64.8 x 35.6 x 40.6cm)
Interior dimensions (L x W x H):	13.4 x 12 x 9.5" (34 x 30.5 x 24.1cm)
Tray dimensions (L x W):	13 x 11" (33 x 27.9cm)
Electrical (50/60 Hz):	120 volts, 5 amps, 450 watts 230 volts, 5 amps, 450 watts
Fuses:	5mm x 20mm, 5 amp quick acting
Temperature range:	ambient +5°C to 65°C
Temperature uniformity:	±0.5°C at 37°C
Speed range:	15 to 500rpm
Speed accuracy:	
Above 100rpm	±1% of set speed
Below 100rpm	±1rpm
Timer:	1 second to 9999 minutes (increased in 1 second increments)
Orbit:	0.75" (19mm)
Capacity:	~35lbs (16kg) @ 75rpm ~5lbs (2.3kg) @ 500rpm
Controls:	see page 4
Tray material:	aluminum
Ship weight:	83lbs (37.7kg)

SPECIFICATIONS - symphony™ INCUBATING ORBITAL MODEL 5000I

Overall dimensions (L x W x H):	32.1 x 26.6 x 23.5" (81.5 x 67.6 x 59.7cm)
Interior dimensions (L x W x H):	20.6 x 24.8 x 17" (52.3 x 63 x 43.2cm)
Tray dimensions (L x W):	18 x 18" (45.7 x 45.7cm)
Electrical (50/60 Hz):	120 volts, 8 amps, 800 watts 230 volts, 8 amps, 800 watts
Fuses:	5mm x 20mm, 8 amp quick acting
Temperature range:	ambient +5°C to 65°C
Temperature uniformity:	±0.5°C at 37°C
Speed range:	15 to 500rpm
Speed accuracy:	
Above 100rpm	±1% of set speed
Below 100rpm	±1rpm
Timer:	1 second to 9999 minutes (increased in 1 second increments)
Orbit:	1" (25mm)
Capacity:	~50lbs (22.7kg) @ 125rpm ~10lbs (4.53kg) @ 500rpm
Controls:	see page 4
Tray material:	aluminum
Ship weight:	215lbs (97.5kg)

**SPECIFICATIONS - symphony™ INCUBATING REFRIGERATING ORBITAL
MODEL 5000IR**

Overall dimensions (L x W x H):	41.1 x 26.6 x 23.5" (104.4 x 67.6 x 59.7cm)
Interior dimensions (L x W x H):	20.6 x 24.8 x 17" (52.3 x 63 x 43.2cm)
Tray dimensions (L x W):	18 x 18" (45.7 x 45.7cm)
Electrical (50/60 Hz):	120 volts, 10 amps, 800 watts 230 volts, 10 amps, 800 watts
Fuses:	5mm x 20mm, 10 amp quick acting
Refrigerant:	R404A, 7.1oz. by weight
Temperature range:	ambient -15°C to 65°C
Temperature uniformity:	±0.5°C at 37°C
Speed range:	15 to 500rpm
Speed accuracy:	
Above 100rpm	±1% of set speed
Below 100rpm	±1rpm
Timer:	1 second to 9999 minutes (increased in 1 second increments)
Orbit:	1" (25mm)
Capacity:	~50lbs (22.7kg) @ 125rpm ~10lbs (4.53kg) @ 500rpm
Controls:	see page 4
Tray material:	aluminum
Ship weight:	260lbs (117.9kg)

5000IR UPPER AMBIENT CONTROL LIMIT

Please follow the procedure below if setting the 5000IR unit's temperature at/near the room's ambient temperature.

For optimum temperature control in the chamber of the 5000IR unit, the upper ambient control limit is to be set a minimum of 3°C above the measured room temperature.

Example: Measured (ambient) temperature is 22°C, the upper ambient control limit should be set at a minimum of 25°C.

With the unit at the heat/cool setting as described below, and in cool mode ("cool" on time display), a temperature setting is displayed in the temperature window. The default temperature setting of the 5000IR is 28°C. This is the factory set upper ambient control limit. This setting can be adjusted between 20°C and 32°C by the user.

- Any unit set point above the upper limit setting will heat only.
- Any unit set point below 20°C will cool only.
- Any set point between 20°C and the selected upper limit setting, up to 32°C, the chiller and heater will both control chamber temperature.

Heat/Cool Setting Procedure to Adjust Upper Ambient Control Limit

1. Put unit in standby mode.
2. Press and hold the speed down and time down arrows simultaneously, now press the standby button. Release all buttons.
3. Time display will now read "cool" and the temperature display will read 28°C. If the time display reads "heat" press the time up/down arrow until the word "cool" appears in the display.

4. Now you can set the upper ambient control limit. Using the temperature up/down arrows adjust this temperature to be 3°C above the measured ambient temperature.
5. Once the desired temperature is selected, press the standby button to return to normal operation.
6. This procedure does not require recalibrating the unit.

Additional 5000IR Notes:

- 5000IR units have a toggle switch on the left side. This switch must be in the "on" position (depress "I") for the unit to function properly.
- For 5000IR units, make sure the chiller's hose is positioned to drain freely (into a sink when possible).
- Do not allow the end of the chiller hose to become submerged.
- If chiller hose is positioned in a drain container, the container should have a volume of at least 2 gallons if the unit will be unattended for 48 hours.

OPERATING INSTRUCTIONS

The Incubating Orbital Shaker has been designed for the temperature, speed and time functions to work independently of one another. The temperature and speed can be reset without resetting the timer and the timer can be stopped and started without interrupting the heating and shaking functions.

1. Getting ready:

- a. Plug the power cord into a properly grounded outlet. The standby indicator light will illuminate, verifying power to the unit.

- b. Press the standby button to move the unit from standby mode.



The standby indicator light will turn off and the temperature, speed and time displays will illuminate, displaying the previously used settings.

NOTE: 5000IR units have a toggle switch on the left side. This switch must be in the “on” position (depress “I”) for the unit to function properly.

NOTE: See the procedure on page 7 for 5000IR units that will have the chamber temperature set at/near the ambient temperature.

2. Setting temperature:

- a. Press the up/down arrows below the temperature display until you reach the desired temperature. When you release the button, the display will blink off and then on indicating the new set temperature has been accepted.

- b. Press the on/off button to start the heating function. The indicator light below the temperature display will illuminate to indicate the heating function is in use and remain lit until heating has ceased.

- c. Temperature adjustments can be made without interrupting heating by using the up/down arrows below the temperature display. After the change has been made and you release the button, the display

will blink off and then on indicating the new set temperature has been accepted.

- d. To stop the heating function, press the on/off button below the temperature display. The heat indicator light will turn off.



CAUTION HOT indicator:

The caution hot indicator light warns that the temperature of the air in the chamber is above 40°C (104°F). The light will illuminate and remain lit when the temperature of the air in the chamber reaches approximately 40°C (104°F). When the heat is turned off, the caution hot indicator light will stay lit until the temperature of the air in the chamber is less than 40°C (104°F).

3. Setting speed:

- a. Press the up/down arrows below the speed display until you reach the desired speed. When you release the button, the display will blink off and then on indicating the new set speed has been accepted.

- b. Press the on/off button to start the shaking function. The indicator light below the speed display will illuminate and blink until the set-point is reached. Once the set-point is reached the light will stop blinking and remain lit until shaking has ceased. The micro-processor controlled ramping feature slowly increases speed until the set-point is reached which helps to avoid splashing, and provides excellent low end control.

- c. Speed adjustments can be made without interrupting shaking by using the up/down arrows below the speed display. After the change has been made and you release the button, the display will blink off and then on indicating the new set speed has been accepted.

- d. To stop the shaking function, press the on/off button below the speed display. The speed indicator light will turn off.

4. **Setting time to zero (0:00) and continuous mode:** Accumulated time.
 - a. Press and hold the on/off button below the time display. After three (3) seconds the display will indicate the previous set time.
 - b. Simultaneously press both the up and the down arrows, the display will indicate zero (0:00). The unit time is now set to zero (0:00) minutes. Alternately, you can use the up/down arrows to get to zero (0:00).
 - c. Press the on/off button below the time display. The display will indicate accumulated time. The up/down arrows will become inactive. To stop timer, press the on/off button again. **IMPORTANT:** This will **NOT** interrupt the shaking or heating functions. Press the on/off button below the speed or temp displays to interrupt that function.
 - d. To reset, press and hold the on/off button below the time display. After three (3) seconds the display will indicate the previous set time, which was zero (0:00).

5. **Setting timed mode:** Programmed time.
 - a. Press the up/down arrows below the time display until you reach the desired time.
 - b. Start this function by pressing the on/off button below the time display. The unit will run for the selected time, the up/down arrows will become inactive while the timer is running. The unit will stop shaking/heating when time display reaches zero (0:00). Four (4) audible beeps will indicate the count down function is complete. The time display will default back to the set time. To repeat for the same time, simply press the on/off button again.
 - c. To interrupt an automatic timing cycle before it is completed, press the on/off button below the time display. The display will flash off and on to indicate the time function is on "hold". **IMPORTANT:** This will **NOT** interrupt the shaking/heating functions. Press the on/off button below the speed or temp displays to interrupt these func-

tions. Restart the timer by pressing the on/off button below the time display. Unit will continue counting down to zero (0:00). When the display reaches zero (0:00), you will hear the four (4) audible beeps that indicate the count down function is complete and the shaking/heating function will cease.

6. **Turning unit off:**

- a. To turn the unit off, press the standby button. The temperature, speed and time displays will be blank, the standby indicator light will illuminate. The Incubating Orbital Shaker should be kept in standby mode when not in use. To completely cut off power to the unit, disconnect the power cord from the unit or unplug from the wall outlet.

OPERATING TIPS

- Opening the lid on the Incubating Orbital Shaker will cause the unit to pause shaking and/or heating. Close the lid and the unit will resume shaking and/or heating at current settings.
- Centering your sample and even weight distribution on the tray helps with balance and stability.
- When possible, samples should be covered to prevent excess condensation inside the incubation chamber. Should condensation occur, the use of a desiccant is recommended.
- As a safety feature, a built-in program will shut power off to the motor if the tray is prevented from rotating, or the unit is overloaded beyond its recommended weight capacity.
- The shaker will automatically restart after a power interruption. Built-in memory maintains the last used temperature, speed and time settings during a power interruption.

LOAD SENSING FUNCTION

The Incubating Orbital Shaker is equipped with a load sensing function that can be activated by the user. This function provides protection against improper positioning of load and maximum load being exceeded. When activated, the unit will automatically sense improper load conditions and slow to a safe running speed, then display that speed followed by an E04 error message on the speed display. The unit will also beep three (3) times every 60 seconds until the error is reset by pressing the speed on/off button. To activate the load sensing function use the following steps:

1. Place the unit in standby mode.
2. Press and hold the speed on/off button and then press and release the standby button. The unit will beep two (2) times, confirming the function is enabled.
3. To restore normal operation, remove AC power to the unit for ten (10) seconds and then restore.

If the E04 error occurs be sure the load is within the maximum specification and properly balanced (centered on tray) and/or reduce sample size/speed before restarting the unit. If the E04 error occurs due to acceptable sample vibration or another vibration source, the vibration sensing function can be disabled as described above.

BEEPER PREFERENCE (muting audible alarm)

To silence beeper operation (except for error codes), with the unit in standby mode, press and hold the time on/off button and press the standby button. Release the standby button first, and then release the on/off button. To restore normal beeper operation, remove AC power to unit for ten (10) seconds and then restore.

TEMPERATURE CALIBRATION PROCEDURE (Single Point)

This procedure is used to fine tune and calibrate the Incubating Orbital Shaker at a specific temperature setting. This process may be repeated for up to three (3) separate set-points. If a fourth calibration set-point is entered, the first set-point entered will be overwritten.

1. Turn unit on.
2. Set desired temperature.
3. Stabilize one (1) hour or more, measuring the temperature with a temperature probe/thermometer centrally located in the chamber.
4. Press and hold standby button, then press the temperature up arrow once. The unit will beep two (2) times, confirming calibration mode. The display will now be flashing.
5. Press the temperature up/down arrows until the display on the unit matches the external temperature probe/thermometer. **(Example:** Desired temperature is 37°C. Set unit at 37°C per step 2. Follow steps 3 & 4. Display reads 37°C and the external temperature probe/thermometer reads higher at 39°C. Push the temperature up arrow so the display will match the external temperature device and also read 39°C. By doing this a biased offset for 37°C will be used when unit is set to 37°C.)
6. Press standby button to exit calibration mode and return to normal heating.

This process may be repeated at the same set-point, multiple times for fine tuning if desired.

The unit will now use the biased offset for that specific temperature setting and increase or decrease temperature accordingly to bring the chamber temperature to set-point. The decimal point of the display will flash to indicate a biased offset is being used. All other temperature settings will use the standard internal calibration. This offset will be stored in memory and retained until reset.

To restore unit to factory setting:

Press and hold the standby button while pressing the temperature down arrow once. The reset will be confirmed with two (2) audible beeps. Press the standby button to exit calibration mode and return to normal heating.

Speed Calibration Procedure:

This procedure is used to self calibrate the symphony™ Orbital Shakers. The tray should be free of any samples, vessels, and accessories prior to calibrating.

1. Turn unit on. Speed and time displays will be illuminated.
2. Press and hold the standby button and momentarily press the speed on/off button. The speed display should read. "CAL".
3. The unit will run for approximately one (1) minute and automatically calibrate.

RS-232 SERIAL PORT

The RS-232 serial port provides two-way communications for data logging and unit control. If you need additional details, please contact Troemner for technical support at: tech_support@troemner.com.

TROUBLESHOOTING

During operation, any rattling or ticking sounds may indicate a loose screw on the tray, a tray attachment or an accessory. All accessories should be sufficiently tightened in place before starting the unit.

<u>Error Code</u>	<u>Cause</u>
E04	Improper positioning of load Maximum load exceeded

See 'Load Sensing Function' (page 11). If the E04 error persists, switch the unit off and contact your VWR representative for repairs.

<u>Error Code</u>	<u>Cause</u>
E03	Drive system failure Mechanical obstruction

Press the standby button to clear this error and remove the mechanical obstruction. If the E03 error persists the reason may be a drive system failure and should **NOT** be addressed by the end user. Switch the unit off and contact your VWR representative for repairs.

<u>Error Code</u>	<u>Cause</u>
E02	RTD shorted or temperature below 0°C (32°F)
E01	RTD open or $\pm 1^\circ\text{C}$ temperature deviation from set-point (after unit has stabilized)

<u>Error Code</u>	<u>Cause</u>
E06	Over Temperature Error

The E02, E01, and E06, errors should **NOT** be addressed by the end user. Switch the unit off and contact your VWR representative for repairs.

<u>Error Code</u>	<u>Cause</u>
E07	Defrost Sensor Error (5000IR Units Only)

E07 error will shut unit off if set temperature is 20°C or below. Unit is still operational with a set above 20°C. E07 error will be indicated every 5 minutes until repaired. Contact VWR representative for repair.

REPLACEMENT PARTS - symphony™ INCUBATING ORBITAL SHAKER MODEL 3500

DESCRIPTION	PART NUMBER		
1. Lid Assembly	880900-00	19. Motor	280633-00
Lid	280632-00	20. V-belt	580000-00
Hinge	180108-00	21. Front Panel Overlay	380625-00
Handle	180106-00	22. Power Supply	380623-00
2. Lift	280516-00	23. Display Board	380624-00
3. Lift Mount	180104-00	24. Line Filter, 230V Only	387022-00
4. Locking Acorn Nut	180105-00	25. IEC Power Entry Module	386122-00
5. Fan Guard	280620-00	5 Amp Fuse (5 x 20mm)	380238-00
6. Grill	280625-00	26. Feet	580002-00
7. Insulation, Front Strip	280605-00	Detachable 92" (234cm) Power Cord:	120V 330100-00
8. Insulation, Sides and Back	280606-00		EURO 330101-00
9. Safety Switch	280509-00		UK 330102-00
10. Heater, 120V	380620-00		SWISS 330103-00
230V	380621-00		
11. Thermostat	380723-00		
12. RTD Assembly	380622-00		
13. Fan, 120V	280514-00		
230V	280515-00		
14. Insulation, Left Side	280600-00		
15. Insulation, Right Side	280601-00		
16. Rubber Mat (13 x 11")	480004-00		
17. Tray	280505-00		
18. Knurled Thumbscrew (#10-32 x 0.75")	180101-00		

REPLACEMENT PARTS - symphony™ INCUBATING ORBITAL SHAKER

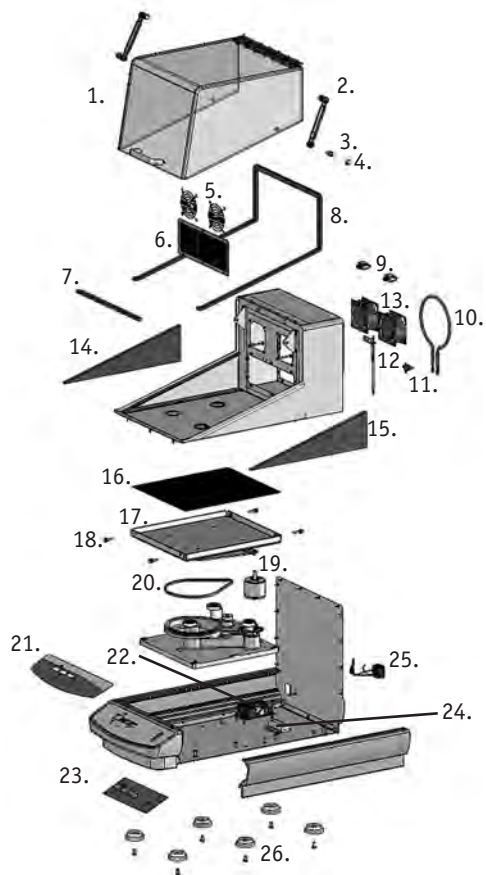

REPLACEMENT PARTS - symphony™ INCUBATING ORBITAL MODEL 5000I

DESCRIPTION	PART NUMBER		
1. Lid	280667-00	20. 18 x 18 Tray	280656-00
2. Gas Lift	280666-00	21. Motor	280633-00
3. Ball Stud	180104-00	22. V-Belt	280513-00
4. Locking Acorn Nut	180105-00	23. Membrane Switch	380625-00
5. Axial Fan Guard	280620-00	24. Printed Circuit Board, Digital	380658-00
6. Insulation Side & Back Strip	280644-00	25. Rubber Foot	580017-00
7. Pushbutton Switch	280509-00	26. Power Supply	380623-00
8. Air Baffle	280672-00	27. Line Filter, 230V Only	387022-00
9. Long Baffle	280682-00	Detachable 92" (234cm) Power Cord:	120V 330100-00
10. Power Wire Assembly 120V	380646-00		EURO 330101-00
230V	380657-00		UK 330102-00
8 Amp Fuse (both units)	380667-00		SWISS 330103-00
11. Insulation, Front Strip	280650-00		
12. Side Insulation, Left Side	280648-00		
13. Axial Fan 120V	280514-00		
230V	280515-00		
14. Heater 120V	380620-00		
230V	380621-00		
15. Disc Thermostat	380723-00		
16. RTD Assembly w/Bracket & Connector	380660-00		
17. Insulation, Right Side	280649-00		
18. Mat	480006-00		
19. Knob	580001-00		

REPLACEMENT PARTS - symphony™ INCUBATING ORBITAL MODEL 5000I

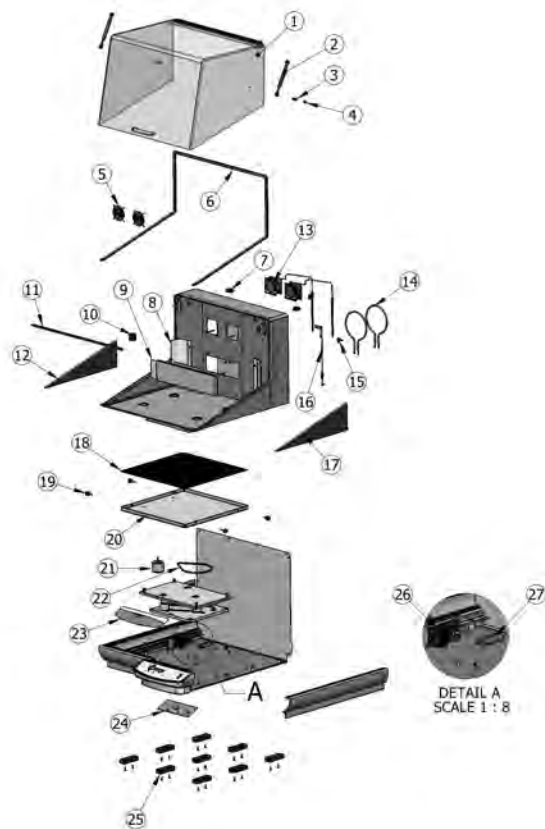

REPLACEMENT PARTS - symphony™ INCUBATING REFRIGERATING ORBITAL SHAKER MODEL 5000IR

DESCRIPTION	PART NUMBER		
1. Lid	280667-00	21. Membrane Switch	380625-00
2. Gas Lift	280666-00	22. Printed Circuit Board	380658-00
3. Ball Stud	180104-00	23. Rubber Foot	580017-00
4. Locking Acorn Nut	180105-00	24. Power Supply	380623-00
5. RS 232 Serial Port Cable	380661-00	25. Line Filter, 230V Only	387022-00
6. Power Wire Assembly 120V	380665-00	26. Pushbutton Switch	280509-00
230V	380657-00	27. Insulation Front Strip	280650-00
10 Amp Fuse (both units)	386005-00	Detachable 92" (234cm) Power Cord:	120V 330100-00
7. Insulation, Left Side	280648-00		EURO 330101-00
8. Lower Baffle	280680-00		UK 330102-00
9. Air Baffle	280672-00		SWISS 330103-00
10. Top Baffle	280677-00		
11. Air Baffle, Right Side	280678-00		
12. Insulation Side & Back Strip	280644-00		
13. Insulation, Right Side	280649-00		
14. Chiller 120V	280675-00		
230V	280676-00		
15. RTD Sensor Assembly	380660-00		
16. Mat	480006-00		
17. Knob	580001-00		
18. 18 x 18 Tray	280656-00		
19. V-Belt	280513-00		
20. Motor	280633-00		

REPLACEMENT PARTS - symphony™ INCUBATING REFRIGERATING ORBITAL SHAKER MODEL 5000IR

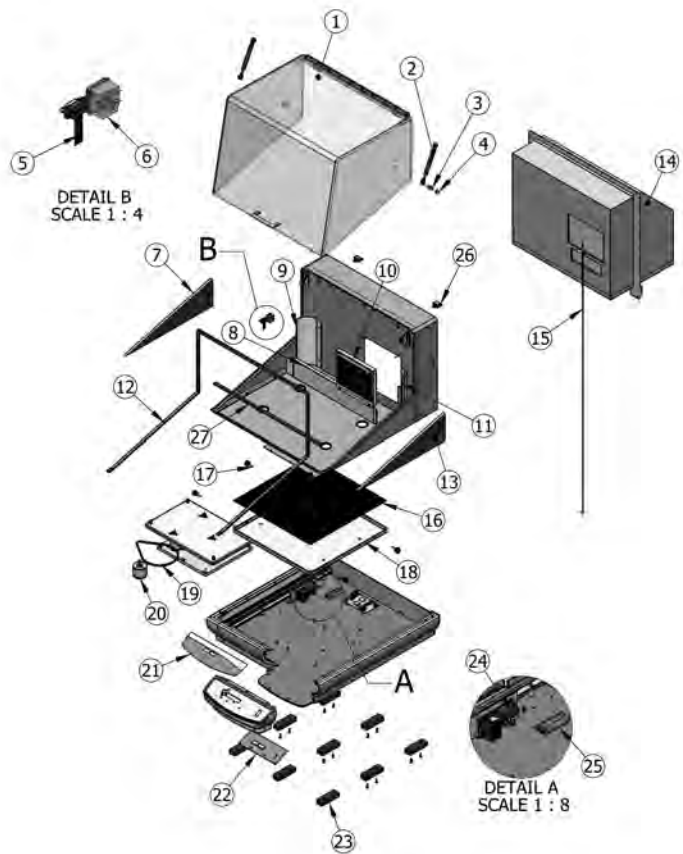

ACCESSORIES

PLATFORM USAGE CHART

PLATFORM SIZE	PLATFORM TYPE	PART NUMBER	USED ON SHAKER MODEL NUMBERS
11 x 13"	Universal	89027-702	symphony™ Incubating Orbital Shaker
18 x 18"	Universal	97021-954	symphony™ Model 5000I, 5000IR

TEST TUBE RACK PLATFORM CAPACITY

Half Size Stationary		1.5 to 2mL Microtube Rack capacity = 70 12620-952	10 to 13mm Test Tube Rack capacity = 63 12620-956	14 to 16 mm Test Tube Rack capacity = 48 12620-958	18 to 20 mm Test Tube Rack capacity = 35 12620-960	22 to 25 mm Test Tube Rack capacity = 24 12620-962	15mL Centrifuge Test Tube Rack capacity = 35 11301-134	50mL Centrifuge Test Tube Rack capacity = 12 11301-136
PLATFORM SIZE	PART NUMBER							
11x13	89027-702	2	2	2	2	2	2	2
18x18	97021-954	4	4	4	4	4	4	4

Full Size Stationary		10 to 14mm Test Tube Rack capacity = 48 14215-240	16 to 20mm Test Tube Rack capacity = 33 14215-242	21 to 25mm Test Tube Rack capacity = 21 14215-244	50mL Centrifuge Test Tube Rack capacity = 17 12985-052
PLATFORM SIZE	PART NUMBER				
11x13	89027-702	N/A	N/A	N/A	N/A
18x18	97021-954	3	3	3	3

Full Size Pivoting		13mm Test Tube Rack capacity = 90 97003-636	16mm Test Tube Rack capacity = 60 97003-638	20mm Test Tube Rack capacity = 40 97003-640	25mm Test Tube Rack capacity = 24 97003-642	30mm Test Tube Rack capacity = 21 97003-644
PLATFORM SIZE	PART NUMBER					
11x13	89027-702	1	1	1	1	1
18x18	97021-954	2	2	2	2	2

ACCESSORIES

FLASK CLAMP PLATFORM CAPACITY

Stainless Steel Erlenmeyer Flask Clamps

PLATFORM SIZE	PART NUMBER	10mL	25mL	50mL	125mL	250mL	500mL	1L	2L	2.8L	4L	6L
		57018-775	57018-786	57018-797	57018-800	57018-811	57018-822	14215-224	14215-226	14215-228	14215-230	14215-232
11x13	89027-702	60	25	13	10	9	7	4	N/A	N/A	N/A	N/A

Stainless Steel Media Bottle Clamps

PLATFORM SIZE	PART NUMBER	500mL	1L
		14215-236	14215-238
11x13	89027-702	5	2
18x18	97021-954	16	10

PVC Erlenmeyer Flask Clamps

PLATFORM SIZE	PART NUMBER	125mL	250mL	500mL	1L	2L
		97003-576	97003-578	97003-580	97003-582	97003-584
11x13	89027-702	10	8	5	2	N/A
18x18	97021-954	20	18	12	8	4

Microplate Clamp

PLATFORM SIZE	PART NUMBER	MICROPLATE CLAMP
		97003-634
11x13	89027-702	4
18x18	97021-954	12

MANUFACTURED BY:

HENRY TROEMNER LLC

201 Wolf Drive • PO Box 87 • Thorofare, NJ 08086-0087
Phone: 856-686-1600 • Fax: 856-686-1601 • E-mail: troemner@troemner.com
www.troemner.com

715063-00 (REV 9 - 03/11)